

MESSRS. : _____

AGENT : _____

**SPECIFICATION
of
THERMOPILE
INFRARED SENSOR**

MODEL NO. : A3D01S-FU-50-60

PART NO. : _____

 **NIPPON CERAMIC CO., LTD.**176-17 Hirooka, Tottori-shi, 689-1193 JAPAN
TEL : +81-857-53-4666 FAX : +81-857-53-3532

APPROVED BY	CHECKED BY	DRAWN BY

MODEL NO. : A3D01S-FU-50-60	DRAWING NO. :	REV : A	PAGE 1 / 11	 NIPPON CERAMIC CO., LTD.
PART NO. :				

5. ELECTRICAL CHARACTERISTICS

Table 2

PARAMETER	CONDITION	SPECIFICATION
5.1. Thermopile Signal Output	Object Temp. : 40.0 degrees Celsius Ambient Temp. : 25.0 degrees Celsius Distance : 250 mm	40.0 °C ± 2.0 °C
5.2. Temperature Characteristics of Thermopile Signal Output	Object Temp. : -30 ~ 400 degrees Celsius	See Data 1
5.3. Temperature Characteristics of Thermistor Signal Output	Ambient Temp. : -20 ~ 100 degrees Celsius	See Data 2
5.4. Supply Voltage	Single Power Supply	5.0V (±10%) (Maximum Rating : 6 V)
5.5. Current Consumption	+Vs = 5.0V Supply	Max. 5 mA
5.6. Output Current	Short Circuit to Ground	Max. 60 mA

6. MEASUREMENT METHOD

Thermopile Signal Output
See Fig. 3.

7. RoHS compliance

This product conforms to the RoHS Directive in force at the date of issuance of this Specification Sheet.

8. Inspection

Process inspection
100% inspection. : Item 5.1 among the electric performances of the 5th items.

9. Packing

Packing specification is shown on Page 11.

10. Action at the time of defective occurrence

When defective occurs in incoming inspection and/or process inspection after the delivery, please return products with accompanying defective description note. We will analyze the defective cause regardless of your extra process on the defective products and decide the accounting action after discussion of both parties according to the defective cause.

11. Consultation item

Modification of this specification shall be made by document after consultation between your company and NIPPON CERAMIC.

MODEL NO. : A3D01S-FU-50-60	DRAWING NO. :	REV : A	PAGE 3 / 11	 NIPPON CERAMIC CO., LTD.
PART NO. :				

12. Notes

12.1. Observance matters on final product design

- 12.1.1. Since this unit is designed supposing indoors use, when used outdoors, please be sure to apply suitable supplementary optical filter, drip-proof and anti-dew construction into the final product design.
- 12.1.2. In cases where secondary accidents due to operation failure or malfunctions can be anticipated, please add a fail safe function to the final product design.

12.2. Precautions on usage

Please use this product fully understanding that there are risks to cause malfunction, operation error and performance degradation in the use under the following conditions or their similar conditions.

- 12.2.1. Use in rapid environmental temperature change.
- 12.2.2. Use in strong shock or vibration.
- 12.2.3. Use in the obstacles (glass, fog) which do not let infrared rays pass in the detection area of the sensor unit.
- 12.2.4. Use in fluid, corrosive gases and sea breeze.
- 12.2.5. Continual use in high humidity atmosphere.
- 12.2.6. Use in direct sun light, headlights of automobiles or etc.
- 12.2.7. Use in direct wind of Heater, Air Conditioner or etc.

12.3. Prohibition matters on handling and storage

Since appearance damage, malfunction, operation error or performance degradation is caused, please definitely avoid the operation and storage under the following conditions or the similar conditions.

- 12.3.1. Condition in vibration for a long time.
- 12.3.2. Condition in strong shock.
- 12.3.3. Place in static electricity or strong electromagnetic waves.
- 12.3.4. Place in high humidity atmosphere for long time.
- 12.3.5. Place in corrosive gases or sea breeze.
- 12.3.6. Place in dusty environments that may contaminate and damage the sensor optics.

12.4. Notice

- 12.4.1. This product does not have the specification corresponding to the use which requires very advanced reliability (life support system and etc.) which is concerned with a human life.
- 12.4.2. These specifications guarantee the quality in the sensor unit itself. Please surely perform evaluation and verification in the state where it has been integrated in the final product of your company before production use.
- 12.4.3. Please understand that we cannot take responsibility of the fault produced by having deviated from the written contents of this specification and having used this unit.
- 12.4.4. The product described in this document shall not be used or embedded to any downstream products of which manufacture, use and / or sales are prohibited under any applicable laws and regulations.

MODEL NO. : A3D01S-FU-50-60	DRAWING NO. :	REV : A	PAGE 4 / 11	 NIPPON CERAMIC CO., LTD.
PART NO. :				

13. Communication specification

13.1. SMBus Communication facility summary

Item	Limitation	Details
Transmission speed	10~100k[Hz]	SMBus conforms method
Protocol supported	See 13.2.	
Slave address	0x3D(7bit 011 1101)	It is non-ARP-compliant.Reply to only slave address(0x3D).
Non-compliant specifications	<ul style="list-style-type: none"> • ARP non-compliant • UDID non-compliant • PEC compliant 	
Others	Time-out	When 30mS continues , and SCL becomes Low , it is reset SMBus interface cercuit and wait for Start Conditions.
	Data length , Turn of data	The data length is 16bit. It is transmitted a data to 8bit by MSB first.
Voltage	Supply voltage is 5.0V(4.5~5.5V).	The threshold of SMBus : VIL = ~0.61V , VIH = 3.18V~

13.2. Bus Protocol

Protocol	Compliant	Remarks
Quick command	X	
Send byte	X	
Receive byte	X	
Write byte/Word	Δ	It support only writing of Word(16bit).
Read byte/Word	Δ	It support only reading of Word(16bit).
Process call	X	
Block write/read	X	
SMBus host notify protocol	X	
Address resolution protocol	X	
I2C Block read/write	X	

13.3. AC Characteristics

Item	Mark	Terms	M I N	T Y P	M A X	Unit	Mesurement Terminal
SCL clock frequency	f_SCL	—	10	—	100	kHz	SCL
Time between STOP-START	t_BUF	—	4.7	—	-	μs	SDA
Hold time after the START	t_HD:STA	—	4	—	-	μs	SCL,SDA
Start setup time	t_SU:STA	—	4.7	—	-	μs	SCL,SDA
Stop setup time	t_SU:STO	—	4	—	-	μs	SCL,SDA
Data hold time	t_HD:DAT	—	300	—	-	ns	SCL,SDA
Data setup time	t_SU:DAT	—	250	—	-	ns	SCL,SDA
Time-out time	t_TIMEOUT	—	-	30	-	ms	SCL,SDA
Clock low period	t_LOW	—	4.7	—	-	μs	SCL
Clock high period	t_HIGH	—	4	—	50	μs	SCL
Clock rese-up time	t_R	—	-	—	1000	ns	SCL
Clock fall-down time	t_F	—	-	—	300	ns	SCL

13.4. Protocol

A Acknowledge	S Start condition	WR Write
NA Not Acknowledge	P Stop condition	RD Read
	Sr Repeat start condition	

S	Address(7bit)	WR	A	command(8bit)	A	data(8bit)	A	data(8bit)	A	data(8bit)	A	P
	0x3D	0	0	OTP/Register address(8bit)	0	data(8bit) L	0	data(8bit) H	0	PEC(8bit)	0	

S	Address(7bit)	WR	A	command(8bit)	A	Sr	Address(7bit)	RD	A	data(8bit)	A	data(8bit)	A	data(8bit)	A	P
	0x3D	0	0	OTP/Register address(8bit)	0		0x3D	1	0	data(8bit) L	0	data(8bit) H	0	PEC(8bit)	0	

MODEL NO. : A3D01S-FU-50-60	DRAWING NO. :	REV : A	PAGE 5 / 11	 NIPPON CERAMIC CO., LTD.
PART NO. :				

13.5. Digital output specification

13.5.1 Self-temperature (Monitor resistor : 0x70)

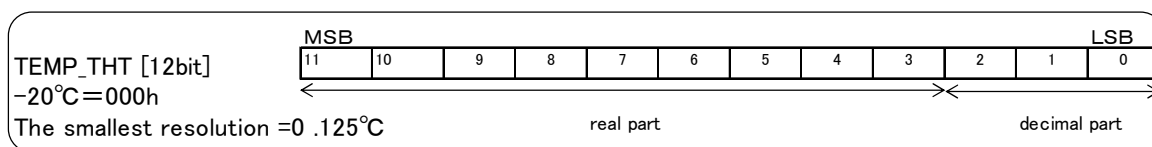

When assume the value that it retrieved "α", the self-temperature is calculated in the following expressions.

$$\text{TEMP_THT}[\text{°C}] = \alpha \div 8 - 20$$

13.5.2 Object temperature (Monitor resistor : 0x71)

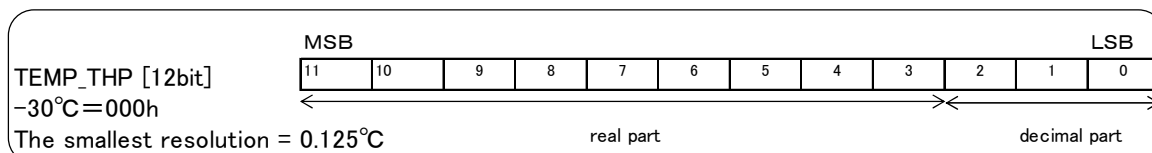

When assume the value that it retrieved "β", the object temperature is calculated in the following expressions.

$$\text{TEMP_THP}[\text{°C}] = \beta \div 8 - 30$$

13.5.2 Object temperature • Stiffness military ration revision result (Monitor resistor : 0x90)

Object temperature • Stiffness military ration revision result (Monitor resistor : 0x90h)

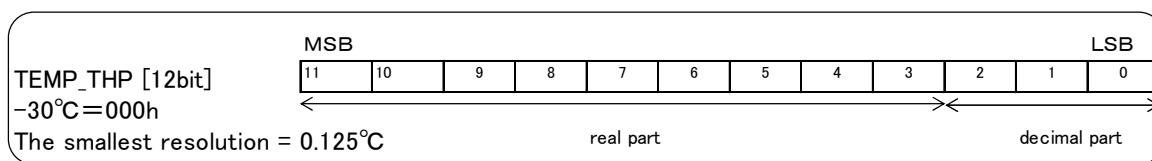

When assume the value that it retrieved "β", the object temperature is calculated in the following expressions.

$$\text{TEMP_THP}[\text{°C}] = \beta \div 8 - 30$$

13.6. Movement timing

Show a movement timing in the chart below. After power supply injection, the first output is after 20.0msec+29.4msec=49.4msec. It update data afterwards every 29.4msec.



MODEL NO. : A3D01S-FU-50-60	DRAWING NO. :	REV : A	PAGE 6 / 11	NIPPON CERAMIC CO., LTD.
PART NO. :				

TOP VIEW

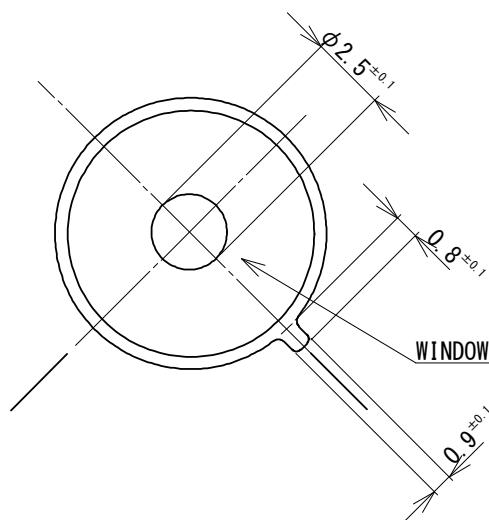

SIDE VIEW

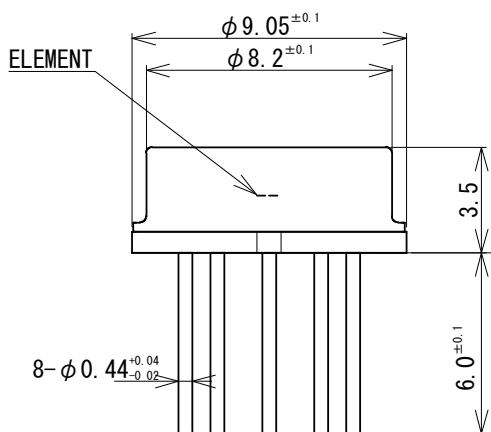

Pin Arrangement

- 1 : VD28
- 2 : +Vs
- 3 : SDA
- 4 : SCL
- 5 : Vtp
- 6 : Vntc
- 7 : VD75
- 8 : Gnd.

BASE VIEW

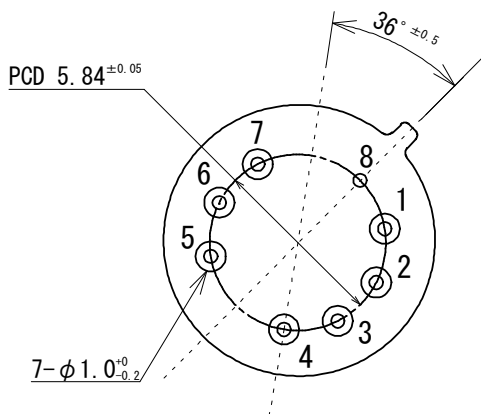

After the necessary circuit
 10uF connected to pin1 ~ 8 between
 and 1uF connected to pin2 ~ 8 between.
 Unless otherwise specified,
 Tolerance : ± 0.2

unit : [mm]

Fig. 1 : Dimensions

MODEL NO. : A3D01S-FU-50-60	DRAWING NO. :	REV : A	PAGE 7 / 11	
PART NO. :				

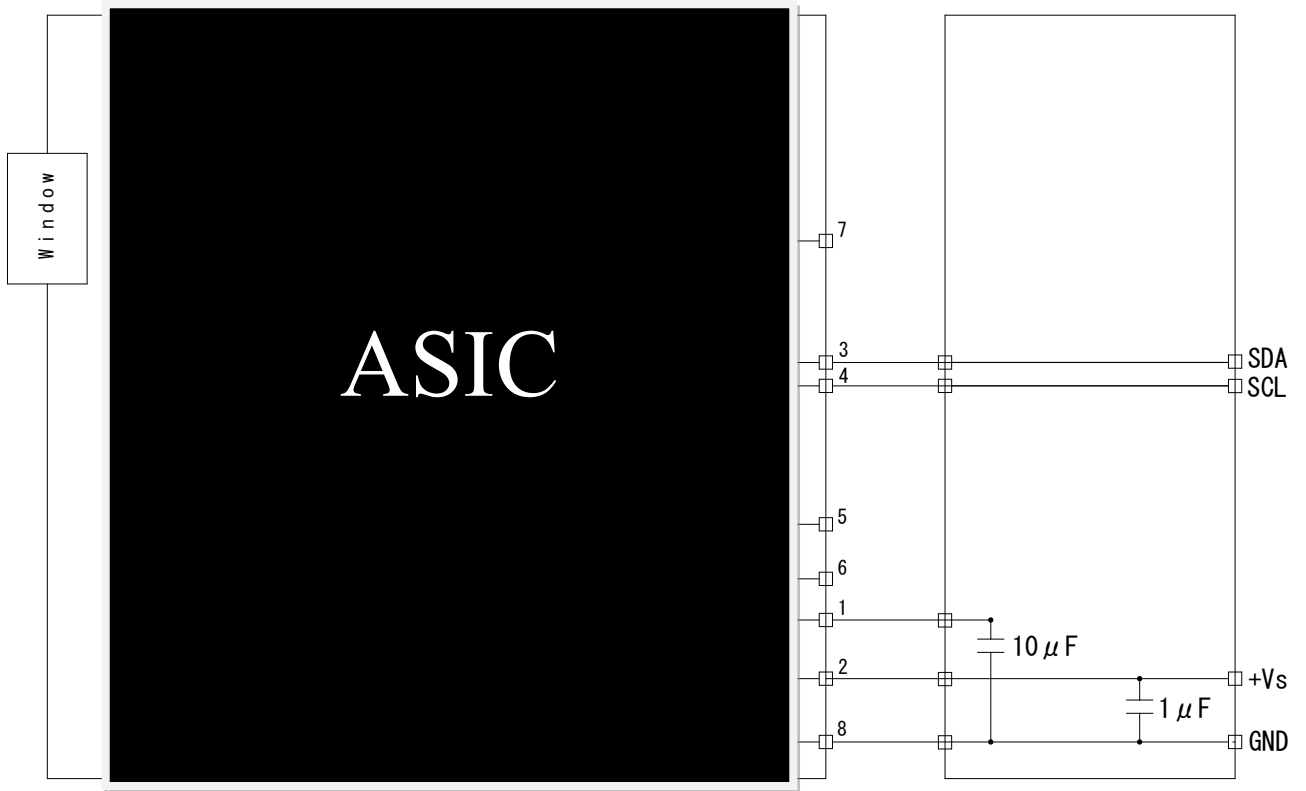

Fig. 2 : Circuit Configuration

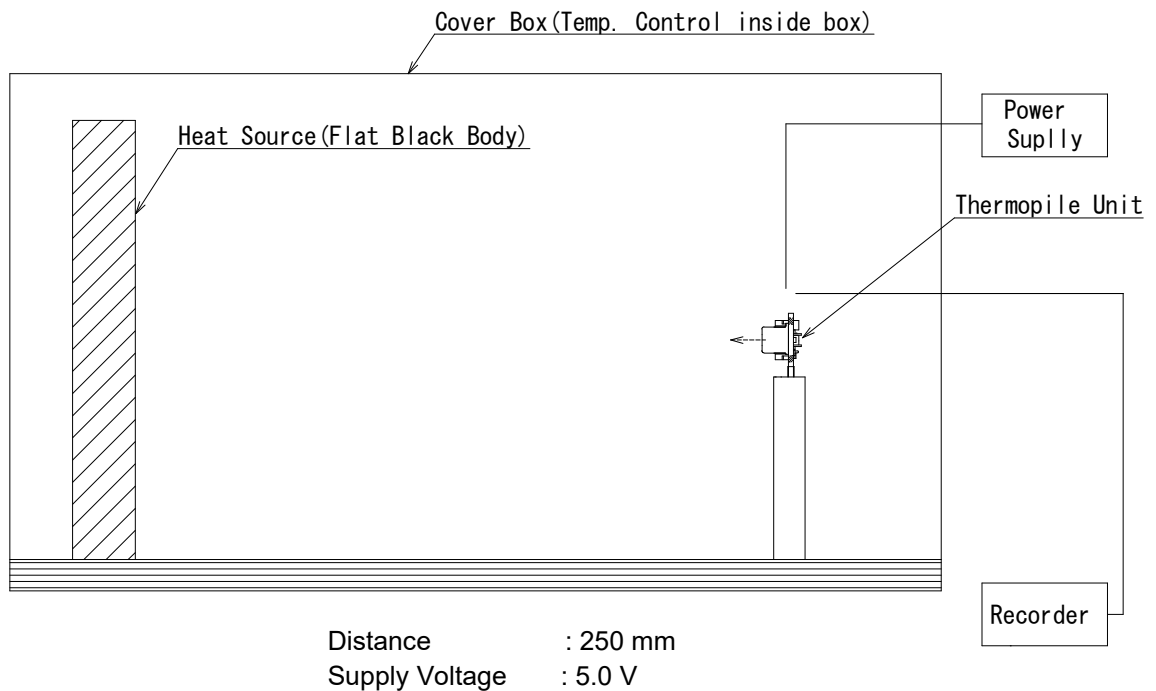

Fig. 3 : Test Set-up Block Diagram

MODEL NO. : A3D01S-FU-50-60	DRAWING NO. :	REV : A	PAGE 8 / 11	
PART NO. :				

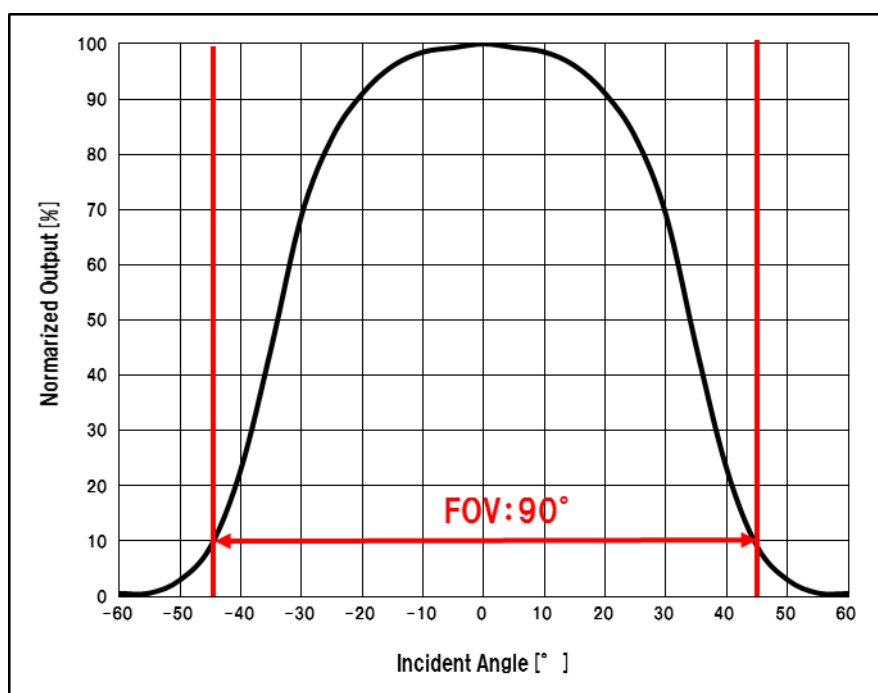
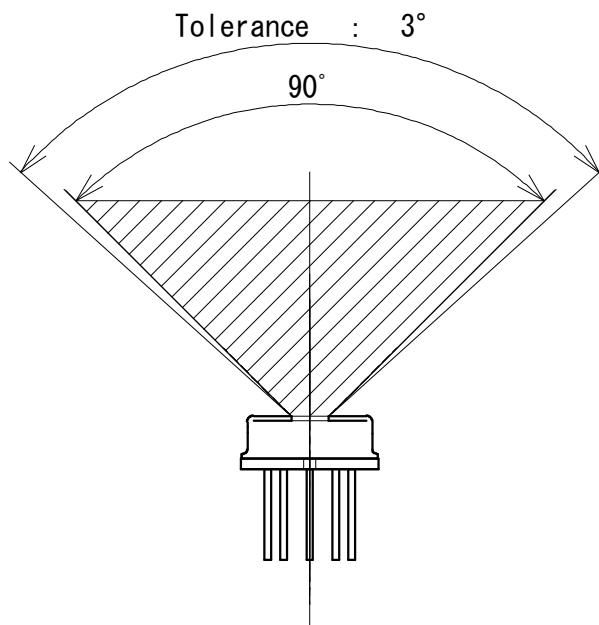
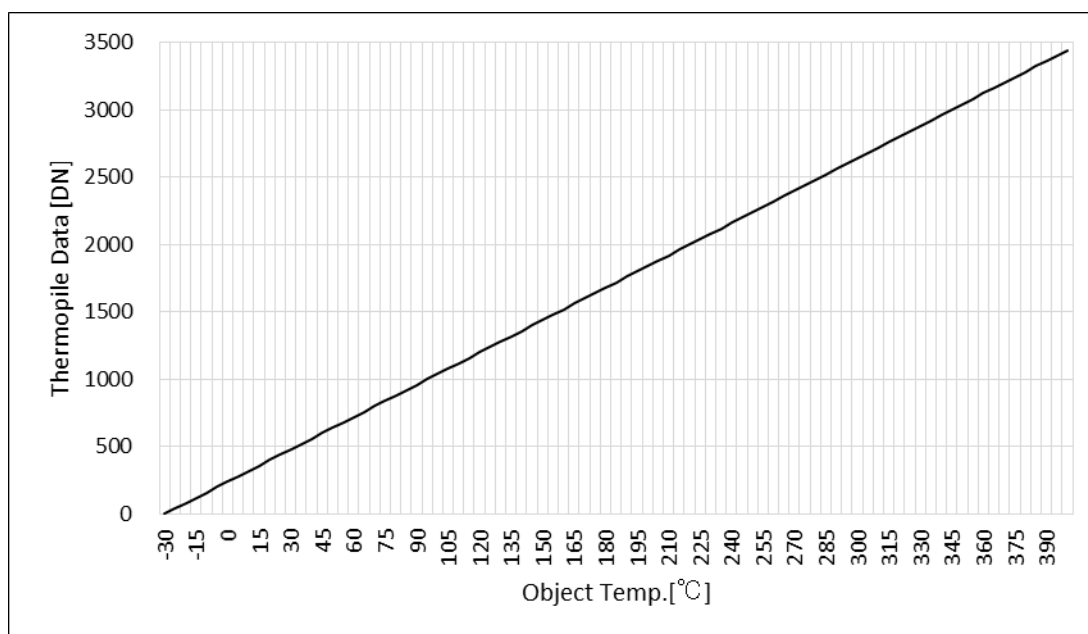

Fig. 4 : Detection Area

MODEL NO. : A3D01S-FU-50-60	DRAWING NO. :	REV : A	PAGE 9 / 11	
PART NO. :				



* Distance : 250 mm

Object Temp.[°C]	-20	0	20	40	60	80	100	120	140	160	180	200	220	240	260	280	300	320	340	360	380	400
data[DN]	80	240	400	560	720	880	1040	1200	1360	1520	1680	1840	2000	2160	2320	2480	2640	2800	2960	3120	3280	3440

Data 1 : Temperature Characteristics of Thermopile Digital Output

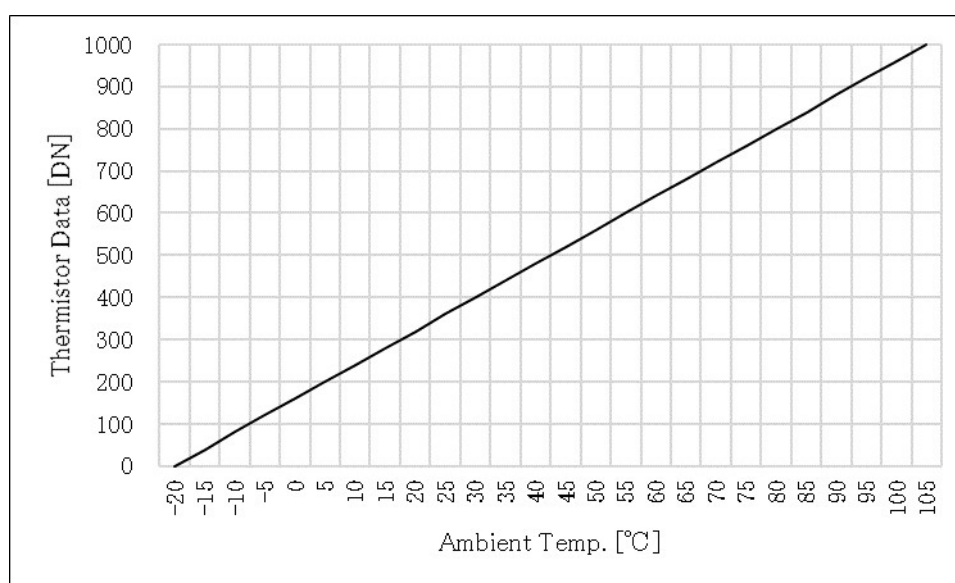

Ambient Temp.[°C]	-20	-10	0	10	20	30	40	50	60	70	80	90	100
data[DN]	0	80	160	240	320	400	480	560	640	720	800	880	960

Data 2 : Temperature Characteristics of Thermistor Signal Output

MODEL NO. : A3D01S-FU-50-60	DRAWING NO. :	REV : A	PAGE 10 / 11	 NIPPON CERAMIC CO., LTD.
PART NO. :				

Packing Specification

The products are packaged in inner box, and the boxes are piled up as shown on the following sketch.

1. Standard Package Quantity : 6,000 pcs.

2. Product arrangement 200 pcs./Sheet
400 pcs./Box

3. Packing

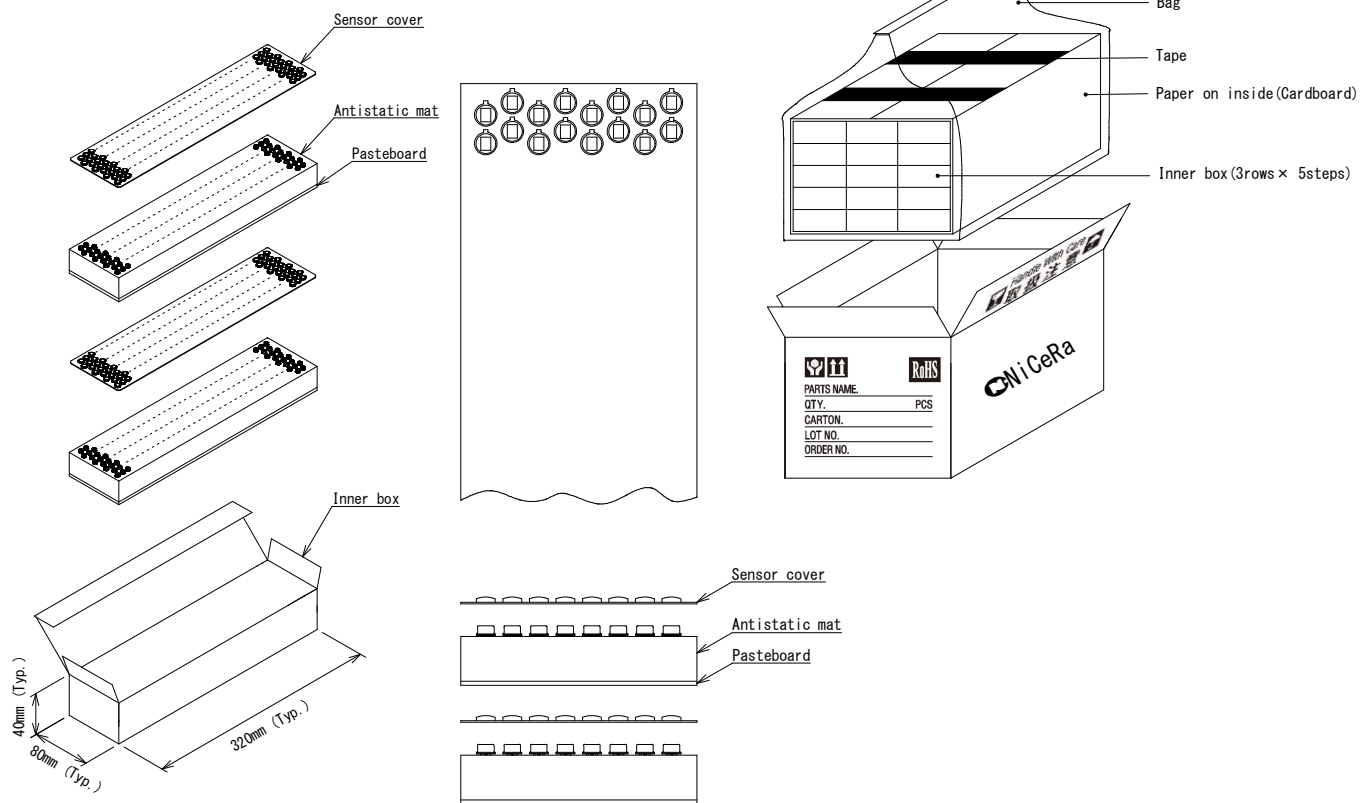

4. Packing in a box

The outer box is sealed with stick tape.

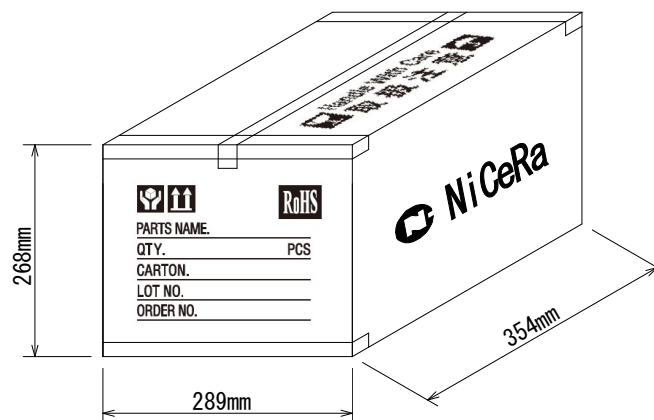

MODEL NO. : A3D01S-FU-50-60	DRAWING NO. :	REV : A	PAGE 11 / 11	NIPPON CERAMIC CO., LTD.
PART NO. :				